

PILOT'S CHECKLIST

# SR22 GTS TURBO

WITH CIRRUS PERSPECTIVE AVIONICS



CIRRUS PERSPECTIVE  
BY GARMIN

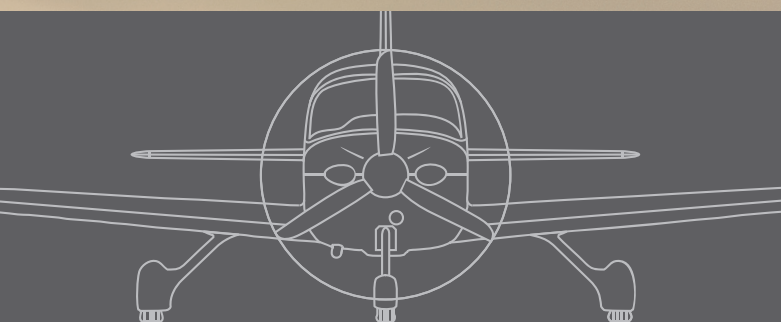

PLANE GENIUS™

# Quick Reference Checklist

for

SR22 Serials 2979 and Subsequent with Perspective Avionics and  
Turbonormalizing System.



The procedures in this publication are abbreviated and derived from procedures in the FAA Approved Airplane Flight Manual and Pilot's Operating Handbook (POH) Original Release. These procedures do not supersede the procedures in the basic POH. In the event of conflict, the basic POH shall take precedence.

  
**Cirrus Design**  
**Normal Checklist**

Airspeeds for Normal Operation .....	N-2
Preflight Inspection .....	N-3
Before Starting Engine .....	N-6
Starting Engine .....	N-7
Before Taxiing .....	N-7
Taxiing .....	N-7
Before Takeoff.....	N-8
Normal Takeoff .....	N-9
Short Field Takeoff.....	N-9
Climb .....	N-9
Cruise .....	N-10
Cruise Climb - Mixture Set at Lean Of Peak.....	N-10
Cruise Leaning .....	N-10
Maximum Cruise Power.....	N-10
Descent .....	N-11
Rapid Descent .....	N-11
Before Landing .....	N-11
Balked Landing/Go-Around .....	N-11
After Landing .....	N-12
Shutdown.....	N-12
Oxygen System Duration.....	N-13

**CIRRUS SR22** *Normal Checklist*

PFD LEGEND

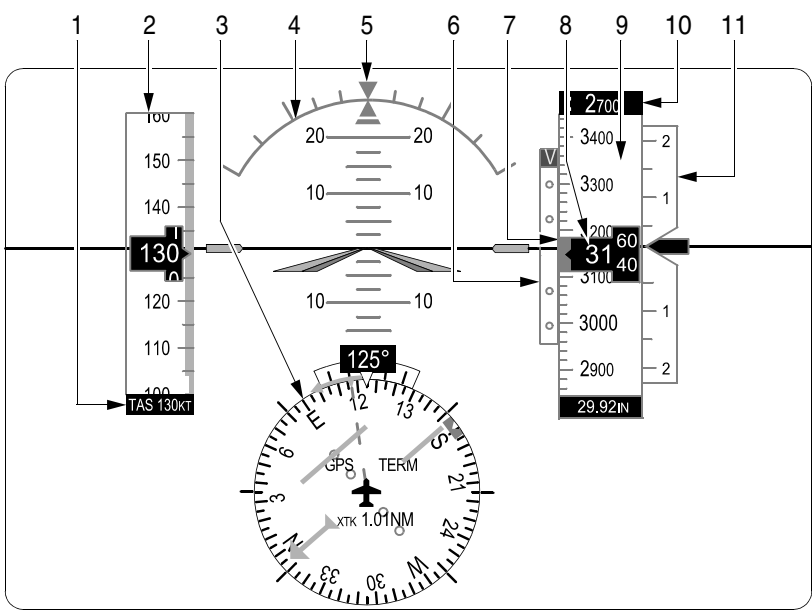

**LEGEND**

- 1. True Airspeed
- 2. Airspeed Indicator
- 3. Horizontal Situation Indicator (HSI)
- 4. Attitude Indicator
- 5. Slip/Skid Indicator
- 6. Vertical Deviation Indicator (VDI)
- 7. Selected Altitude Bug
- 8. Current Vertical Speed
- 9. Altimeter
- 10. Selected Altitude
- 11. Vertical Speed Indicator (VSI)

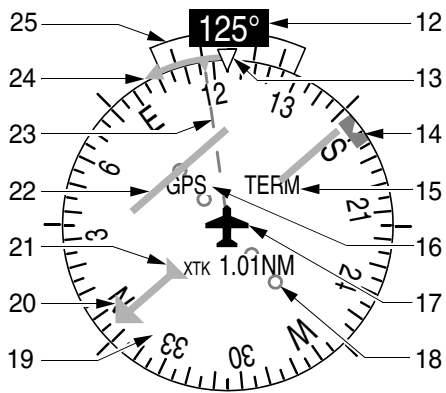

**HSI DETAIL**

- 21. To/From Indicator
- 22. Course Deviation Indicator
- 23. Current Track Indicator
- 24. Turn Rate/Heading Trend Vector
- 25. Turn Rate Indicator

SR22\_FM07\_2790

## Airspeeds for Normal Operation

### Takeoff Rotation:

Normal, Flaps 50% .....	70 KIAS
Obstacle Clearance, Flaps 50% .....	78 KIAS

### Enroute Climb, Flaps Up:

Normal, Full Power, Full Rich Climb .....	120 KIAS
Best Rate of Climb, SL .....	101 KIAS
Best Rate of Climb, 10,000' .....	96 KIAS
Best Angle of Climb, SL.....	79 KIAS
Best Angle of Climb, 10,000' .....	83 KIAS

### Landing Approach:

Normal Approach, Flaps Up .....	90-95 KIAS
Normal Approach, Flaps 50%.....	85-90 KIAS
Normal Approach, Flaps 100%.....	80-85 KIAS
Short Field, Flaps 100% (V <sub>REF</sub> ).....	77 KIAS

### Go-Around, Flaps 50%:

Full Power .....	80 KIAS
------------------	---------

### Maximum Recommended Turbulent Air Penetration:

3400 Lb.....	133 KIAS
2900 Lb.....	123 KIAS

### Maximum Demonstrated Crosswind

Takeoff or Landing .....	20 Knots
--------------------------	----------

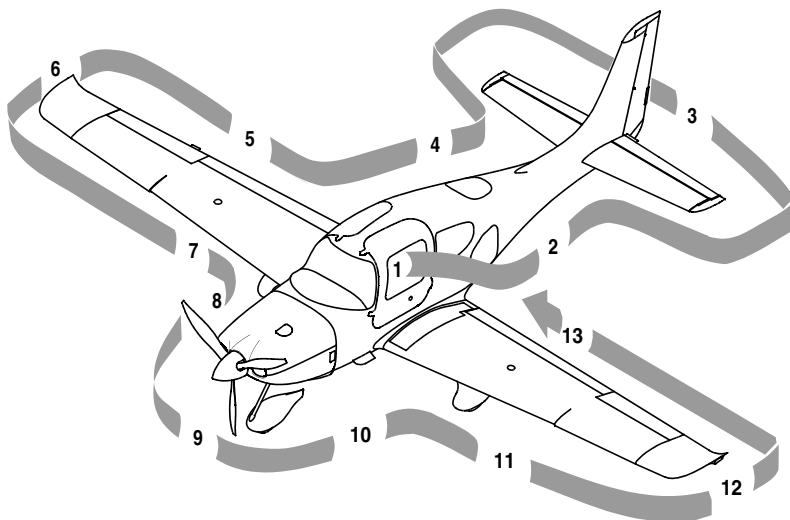

SR22\_FM04\_1454

## Preflight Inspection

1. Cabin
  - a. Required Documents ..... On Board
  - b. Avionics Power Switch ..... OFF
  - c. Bat 2 Master Switch ..... ON
  - d. PFD ..... Verify On
  - e. Avionics Cooling Fan ..... Audible
  - f. Voltmeter ..... 23-25 Volts
  - g. Flap Position Light ..... OUT
  - h. Bat 1 Master Switch ..... ON
  - i. Lights ..... Check Operation
  - j. Stall Warning ..... Test
  - k. Fuel Quantity ..... Check
  - l. Fuel Selector ..... Select Fullest Tank
  - m. Flaps ..... 100%, Check Light ON
  - n. Oil Annunciator ..... On

*(Continued on following page)*

**Preflight Inspection (Continued)**

- o. Bat 1 and 2 Master Switches ..... OFF
  - p. Alternate Static Source ..... NORMAL
  - q. Circuit Breakers..... IN
  - r. Fire Extinguisher ..... Charged and Available
  - s. Emergency Egress Hammer ..... Available
  - t. CAPS Handle ..... Pin Removed
2. Left Fuselage
- a. Door Lock..... Unlock
  - b. COM 1 Antenna (top) ..... Condition and Attachment
  - c. Wing/Fuselage Fairing ..... Check
  - d. COM 2 Antenna (underside) ..... Condition and Attachment
  - e. Baggage Door ..... Closed and Secure
  - f. Static Button..... Check for Blockage
  - g. Parachute Cover ..... Sealed and Secure
3. Empennage
- a. Tiedown Rope ..... Remove
  - b. Horizontal and Vertical Stabilizers..... Condition
  - c. Elevator and Tab ..... Condition and Movement
  - d. Rudder ..... Freedom of Movement
  - e. Rudder Trim Tab..... Condition and Security
  - f. Attachment hinges, bolts and cotter pins ..... Secure
4. Right Fuselage
- a. Static Button..... Check for Blockage
  - b. Wing/Fuselage Fairings ..... Check
  - c. Door Lock..... Unlock
5. Right Wing Trailing Edge
- a. Flap and Rub Strips (if installed) ..... Condition and Security
  - b. Aileron and Tab ..... Condition and Movement
  - c. Aileron Gap Seal ..... Security
  - d. Hinges, actuation arm, bolts, and cotter pins ..... Secure

*(Continued on following page)*

**Preflight Inspection (Continued)**

- 6. Right Wing Tip
  - a. Tip ..... Attachment
  - b. Strobe, Nav Light and Lens..... Condition and Security
  - c. Fuel Vent (underside)..... Unobstructed
- 7. Right Wing Forward and Main Gear
  - a. Leading Edge and Stall Strips..... Condition
  - b. Fuel Cap..... Check Quantity and Secure
  - c. Fuel Drains (2 underside)..... Drain and Sample
  - d. Wheel Fairings ..... Security, Accumulation of Debris
  - e. Tire ..... Condition, Inflation, and Wear
  - f. Wheel and Brakes ..... Fluid Leaks, Evidence of Overheating, General Condition, and Security
  - g. Chocks and Tiedown Ropes ..... Remove
  - h. Cabin Air Vent ..... Unobstructed
- 8. Nose, Right Side
  - a. Vortex Generator ..... Condition
  - b. Cowling ..... Attachments Secure
  - c. Exhaust Pipe ..... Condition, Security, and Clearance
  - d. Transponder Antenna (underside)... Condition and Attachment
  - e. Gascolator (underside)..... Drain for 3 seconds, Sample
- 9. Nose gear, Propeller, and Spinner
  - a. Tow Bar ..... Remove and Stow
  - b. Strut..... Condition
  - c. Wheel Fairing ..... Security, Accumulation of Debris
  - d. Wheel and Tire..... Condition, Inflation, and Wear
  - e. Propeller..... Condition (indentations, nicks, etc.)
  - f. Spinner..... Condition, Security, and Oil Leaks
  - g. Air Inlets ..... Unobstructed
  - h. Alternator ..... Condition
- 10. Nose, Left Side
  - a. Landing Light..... Condition

*(Continued on following page)*

### Preflight Inspection (Continued)

- b. Engine Oil..... Check 6-8 quarts, Leaks, Cap & Door Secure
  - c. Cowling ..... Attachments Secure
  - d. External Power ..... Door Secure
  - e. Vortex Generator..... Condition
  - f. Exhaust Pipe(s)..... Condition, Security, and Clearance
11. Left Main Gear and Forward Wing
- a. Wheel Fairings .....Security, Accumulation of Debris
  - b. Tire ..... Condition, Inflation, and Wear
  - c. Wheel and Brakes .....Fluid Leaks, Evidence of Overheating, General Condition, and Security
  - d. Chocks and Tiedown Ropes ..... Remove
  - e. Fuel Drains (2 underside).....Drain and Sample
  - f. Cabin Air Vent ..... Unobstructed
  - g. Fuel Cap..... Check Quantity and Secure
  - h. Leading Edge and Stall Strips..... Condition
12. Left Wing Tip
- a. Fuel Vent (underside) ..... Unobstructed
  - b. Pitot Mast (underside) ..... Cover Removed, Tube Clear
  - c. Strobe, Nav Light and Lens..... Condition and Security
  - d. Tip ..... Attachment
13. Left Wing Trailing Edge
- a. Flap And Rub Strips (If installed) ..... Condition and Security
  - b. Aileron ..... Freedom of movement
  - c. Aileron Gap Seal ..... Security
  - d. Hinges, actuation arm, bolts, and cotter pins ..... Secure

### Before Starting Engine

- 1. Preflight Inspection ..... COMPLETED
- 2. Weight and Balance..... Verify Within Limits
- 3. Emergency Equipment ..... ON BOARD
- 4. Passengers..... BRIEFED
- 5. Seats, Seat Belts, and Harnesses ..... ADJUST & SECURE

BEFORE STARTING

**Starting Engine**

1. External Power (If applicable) .....CONNECT
2. Brakes ..... HOLD
3. Bat Master Switches .....ON (Check Volts)
4. Strobe Lights ..... ON
5. Mixture .....FULL RICH
6. Power Lever ..... FULL FORWARD
7. Fuel Pump .....LOW BOOST
8. Propeller Area..... CLEAR
9. Power Lever ..... OPEN ¼ INCH
10. Ignition Switch .....START (Release after engine starts)
11. Power Lever ..... RETARD (to maintain 1000 RPM)
12. Oil Pressure.....CHECK
13. Mixture .....LEAN until RPM rises to a maximum value
14. Alt Master Switches ..... ON
15. Avionics Power Switch ..... ON
16. Engine Parameters ..... MONITOR
17. External Power (If applicable) .....DISCONNECT
18. Amp Meter/Indication..... CHECK

**Before Taxiing**

1. Flaps ..... UP (0%)
2. Radios/Avionics .....AS REQUIRED
3. Cabin Heat/Defrost ..... AS REQUIRED
4. Fuel Selector ..... SWITCH TANK

**Taxiing**

1. Parking Brake ..... DISENGAGE
2. Brakes..... CHECK
3. HSI Orientation ..... CHECK
4. Attitude Gyro..... CHECK
5. Turn Coordinator ..... CHECK



**Before Takeoff**

1. Doors ..... LATCHED
2. CAPS Handle ..... Verify Pin Removed
3. Seat Belts and Shoulder Harness ..... SECURE
4. Fuel Quantity ..... CONFIRM
5. Fuel Selector ..... FULLEST TANK
6. Fuel Pump ..... LOW BOOST
7. Mixture ..... AS REQUIRED
8. Flaps ..... SET 50% & CHECK
9. Transponder ..... SET
10. Autopilot ..... CHECK
11. Navigation Radios/GPS ..... SET for Takeoff
12. Cabin Heat/Defrost ..... AS REQUIRED
13. Brakes ..... HOLD
14. Power Lever ..... 1700 RPM
15. Alternator ..... CHECK
  - a. Pitot Heat ..... ON
  - b. Navigation Lights ..... ON
  - c. Landing Light ..... ON
  - d. Annunciator Lights ..... CHECK
16. Voltage ..... CHECK
17. Pitot Heat ..... AS REQUIRED
18. Navigation Lights ..... AS REQUIRED
19. Landing Light ..... AS REQUIRED
20. Magnetos ..... CHECK Left and Right
  - a. RPM drop  $\leq$  150, difference between mags  $\leq$  75 RPM.
21. Engine Parameters ..... CHECK
22. Power Lever ..... 1000 RPM
23. Flight Instruments, HSI, and Altimeter ..... CHECK & SET
24. Flight Controls ..... FREE & CORRECT
25. Trim ..... SET Takeoff
26. Autopilot ..... DISCONNECT

BEFORE TAKEOFF



**Normal Takeoff**

1. Brakes..... RELEASE (Steer with Rudder Only)
2. Power Lever ..... FULL FORWARD
3. Engine Power.....CHECK
  - a. Verify full-throttle engine operation early in takeoff run.
    - The engine should run smoothly and turn approximately 2700 RPM.
4. Engine Parameters .....CHECK
5. Elevator Control ..... ROTATE Smoothly at 70-73 KIAS
6. At 80 KIAS, Flaps ..... UP

**Short Field Takeoff**

1. Flaps..... 50%
2. Brakes ..... HOLD
3. Power Lever ..... FULL FORWARD
4. Mixture..... SET
5. Engine Parameters .....CHECK
6. Brakes..... RELEASE (Steer with Rudder Only)
7. Elevator Control .....ROTATE Smoothly at 70 KIAS
8. Airspeed at Obstacle ..... 78 KIAS

**Climb**

1. Oxygen .....AS REQUIRED
2. Power Lever ..... FULL FORWARD
3. Mixture.....FULL RICH
4. Airspeed ..... Vy
5. Electric Fuel Pump ..... LOW BOOST
6. Fuel Flow ..... MONITOR
7. Engine Parameters ..... MONITOR

**Cruise**

1. Oxygen ..... AS REQUIRED
2. Fuel Pump ..... OFF
3. Cruise Power ..... SET
4. Mixture ..... LEAN as required
5. Engine Parameters ..... MONITOR
6. Fuel Flow and Balance ..... MONITOR

**Cruise Climb - Mixture Set at Lean Of Peak**

1. Oxygen ..... AS REQUIRED
2. Power Lever ..... FULL FORWARD
3. Mixture ..... 17.0 to 17.6 GPH
4. Minimum Airspeed ..... 130 KIAS
5. Electric Fuel Pump ..... LOW BOOST

**Cruise Leaning**

Desired Cruise Setting	Configuration
Maximum Cruise Power	<ul style="list-style-type: none"> <li>• Power Lever - Max available MAP at 2500 RPM</li> <li>• Mixture - 17.6 GPH* (~85% Power)</li> <li>• High CHT reads below 380°F</li> </ul>
Economy Cruise Power	<ul style="list-style-type: none"> <li>• Power Lever - 24" MAP at 2500 RPM</li> <li>• Mixture - 13.0 to 14.5 GPH* (~63% to 69% Power)</li> <li>• High CHT reads below 380°F</li> </ul>

\* Target fuel flow indicator may be used as an aid to set mixture.

**Maximum Cruise Power**

1. Cruise Altitude ..... ESTABLISHED
2. Power Lever ..... 2700 RPM
3. Mixture ..... FULL RICH for 1 to 2 minutes
4. Highest CHT ..... VERIFY LESS THAN 380°F
5. Power Lever ..... 2500 RPM at max available MAP (29.0" to 29.6")
6. Electric Fuel Pump ..... LOW BOOST
7. Mixture ..... FULL RICH
8. Engine Parameters ..... MONITOR
9. Electric Fuel Pump ..... AS REQUIRED



**Descent**

- 1. Altimeter ..... SET
- 2. Cabin Heat/Defrost .....AS REQUIRED
- 3. Landing Light ..... ON
- 4. Fuel System.....CHECK
- 5. Mixture .....AS REQUIRED
- 6. Brake Pressure .....CHECK
- 7. Oxygen .....AS REQUIRED

**Rapid Descent**

- 1. Altimeter ..... SET
- 2. Power Lever ..... Smoothly REDUCE MAP 17 to 20 in.Hg
- 3. Mixture ..... Maintain CHTs above 240°F
- 4. Airspeed .....AS REQUIRED
- 5. Oxygen .....AS REQUIRED

**Before Landing**

- 1. Seat Belt and Shoulder Harness ..... SECURE
- 2. Fuel Pump .....BOOST
- 3. Mixture .....AS REQUIRED
- 4. Flaps .....AS REQUIRED
- 5. Autopilot.....AS REQUIRED

**Balked Landing/Go-Around**

- 1. Autopilot..... DISENGAGE
- 2. Power Lever ..... FULL FORWARD
- 3. Flaps ..... 50%
- 4. Airspeed ..... 75-80 KIAS

*After clear of obstacles:*

- 5. Flaps ..... UP

**After Landing**

- 1. Power Lever ..... 1000 RPM
- 2. Fuel Pump ..... OFF
- 3. Flaps ..... UP
- 4. Transponder ..... STBY
- 5. Lights ..... AS REQUIRED
- 6. Pitot Heat ..... OFF

**Shutdown**

- 1. Fuel Pump (if used) ..... OFF
- 2. Throttle ..... IDLE
- 3. Ignition Switch ..... CYCLE - MAG GROUNDING CHECK
- 4. Mixture ..... CUTOFF
- 5. All Switches ..... OFF
- 6. Magnetos ..... OFF
- 7. ELT ..... TRANSMIT LIGHT OUT
- 8. Chocks, Tie-downs, Pitot Covers ..... AS REQUIRED

# Oxygen System Duration

O2 DURATION

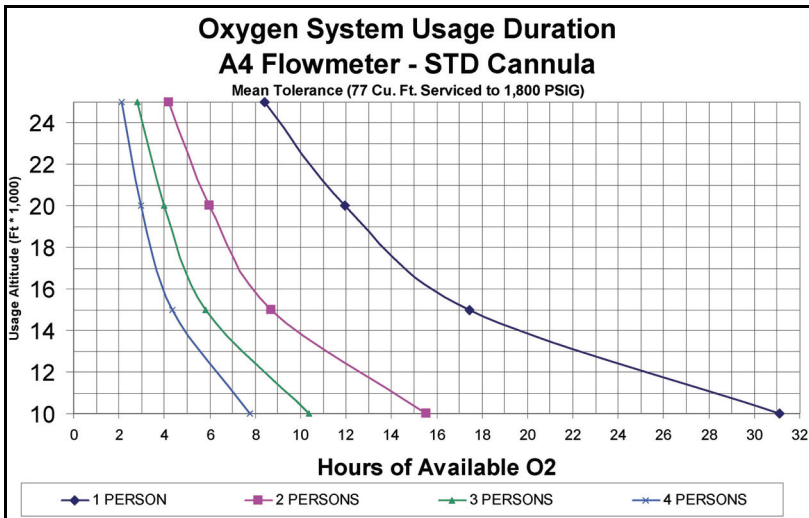

*Cirrus Design*   
**Performance Data**

Takeoff Distance - 3400 LB ..... P-1  
 Takeoff Distance - 2900 LB ..... P-2  
 Cruise Performance ..... P-3  
 Cruise Performance (Continued) ..... P-4  
 Cruise Performance (Continued) ..... P-5  
 Landing Distance ..... P-6  
 Weight and Balance ..... P-7  
 Weight and Balance (Continued) ..... P-8  
 Wind Components ..... P-9



Performance Data

TAKEOFF DISTANCE - 3400 LB

<p><b>Weight:</b> 3400 LB  <b>Speed at Liftoff:</b> 73 KIAS  <b>Speed over 50 Ft. Obstacle:</b> 78 KIAS  <b>Flaps:</b> 50%  <b>Power:</b> Takeoff  <b>Runway:</b> Dry, Paved, Level</p>	<p><b>Headwind:</b> Subtract 10% for each 12 knots headwind.  <b>Tailwind:</b> Add 10% for each 2 knots tailwind up to 10 knots.  <b>Runway Slope:</b> Reference Notes.  <b>Dry Grass:</b> Add 20% to Ground Roll.  <b>Wet Grass:</b> Add 30% to Ground Roll.</p>
---	---

PRESS ALT FT	DISTANCE FT	TEMPERATURE ~ °C					ISA
		0	10	20	30	40	
SL	Grnd Roll	917	990	1067	1146	1229	1028
	50 ft	1432	1539	1650	1764	1883	1594
1000	Grnd Roll	1011	1092	1176	1264	1355	1117
	50 ft	1574	1691	1813	1939	2069	1728
2000	Grnd Roll	1116	1206	1299	1395	1496	1215
	50 ft	1732	1861	1995	2133	2276	1874
3000	Grnd Roll	1234	1332	1435	1542	1653	1323
	50 ft	1907	2049	2196	2349	2507	2035
4000	Grnd Roll	1365	1474	1588	1706	1829	1441
	50 ft	2102	2259	2422	2590	2764	2212
5000	Grnd Roll	1512	1633	1758	1889	2025	1572
	50 ft	2320	2493	2673	2858	3051	2407
6000	Grnd Roll	1676	1810	1950	2095	2245	1717
	50 ft	2564	2755	2953	3159	3371	2622
7000	Grnd Roll	1861	2009	2164	2325	2492	1877
	50 ft	2837	3048	3267	3494	3729	2859
8000	Grnd Roll	2068	2233	2405	2584	2770	2054
	50 ft	3142	3376	3619	3871	4131	3122
9000	Grnd Roll	2302	2485	2677	2875	3082	2250
	50 ft	3485	3744	4014	4293	4581	3412
10000	Grnd Roll	2564	2769	2982	3204	3434	2468
	50 ft	3870	4158	4457	4767	5088	3733

## TAKEOFF DISTANCE - 2900 LB

<b>Weight:</b> 2900 LB <b>Speed at Liftoff:</b> 70 KIAS <b>Speed over 50 Ft. Obstacle:</b> 74 KIAS <b>Flaps:</b> 50% <b>Power:</b> Takeoff <b>Runway:</b> Dry, Paved, Level	<b>Headwind:</b> Subtract 10% for each 12 knots headwind. <b>Tailwind:</b> Add 10% for each 2 knots tailwind up to 10 knots. <b>Runway Slope:</b> Reference Notes. <b>Dry Grass:</b> Add 20% to Ground Roll. <b>Wet Grass:</b> Add 30% to Ground Roll.
--	--

PRESS ALT FT	DISTANCE FT	TEMPERATURE ~ °C					ISA
		0	10	20	30	40	
SL	Grnd Roll	610	659	710	763	818	684
	50 ft	971	1043	1118	1195	1275	1080
1000	Grnd Roll	673	727	783	841	902	743
	50 ft	1066	1146	1228	1313	1401	1170
2000	Grnd Roll	743	802	864	929	995	809
	50 ft	1173	1260	1351	1444	1541	1269
3000	Grnd Roll	821	887	955	1026	1100	880
	50 ft	1292	1388	1487	1590	1697	1378
4000	Grnd Roll	908	981	1057	1135	1217	959
	50 ft	1424	1530	1639	1753	1871	1498
5000	Grnd Roll	1006	1086	1170	1257	1348	1046
	50 ft	1571	1688	1809	1935	2065	1630
6000	Grnd Roll	1116	1205	1298	1394	1494	1143
	50 ft	1736	1865	1999	2138	2281	1775
7000	Grnd Roll	1238	1337	1440	1547	1659	1249
	50 ft	1920	2063	2211	2365	2523	1936
8000	Grnd Roll	1376	1486	1601	1720	1843	1367
	50 ft	2127	2285	2449	2619	2795	2113
9000	Grnd Roll	1532	1654	1781	1914	2051	1498
	50 ft	2359	2534	2716	2904	3099	2309
10000	Grnd Roll	1707	1843	1985	2132	2285	1643
	50 ft	2619	2814	3016	3225	3441	2527

TAKEOFF 2900 LB



# CRUISE PERFORMANCE

**Conditions:**

- Cruise Weight ..... 2900 LB
- Winds ..... Zero

• Note •

Subtract 10 KTAS if nose wheel pant and fairing removed. Lower KTAS by 10% if nose and main wheel pants & fairings are removed.

Aircraft with optional Air Conditioning System - Cruise performance is reduced by 2 knots. For maximum performance, the air-conditioner should be off.

- Shaded data cells: Cruise Power above 85% not recommended.

2000 Feet Pressure Altitude						
Manifold Pressure	Engine Speed	Fuel Flow	Percent Power	ISA - 30° C (-19° C)	ISA (11° C)	ISA + 30° C (41° C)
MAP	RPM	GPH	PWR	KTAS	KTAS	KTAS
29.0-29.5	2500	17.6	85%	162	168	174
26.0-28.0	2500	16.0	75%	155	161	166
22.0-25.0	2500	14.0	65%	147	153	158

4000 Feet Pressure Altitude						
Manifold Pressure	Engine Speed	Fuel Flow	Percent Power	ISA - 30° C (-23° C)	ISA (7° C)	ISA + 30° C (37° C)
MAP	RPM	GPH	PWR	KTAS	KTAS	KTAS
29.0-29.5	2500	17.6	85%	165	171	177
26.0-28.0	2500	16.0	75%	158	164	169
22.0-25.0	2500	14.0	65%	150	156	161

6000 Feet Pressure Altitude						
Manifold Pressure	Engine Speed	Fuel Flow	Percent Power	ISA - 30° C (-27° C)	ISA (3° C)	ISA + 30° C (33° C)
MAP	RPM	GPH	PWR	KTAS	KTAS	KTAS
29.0-29.5	2500	17.6	85%	168	175	181
26.0-28.0	2500	16.0	75%	161	167	173
22.0-25.0	2500	14.0	65%	153	159	164

8000 Feet Pressure Altitude						
Manifold Pressure	Engine Speed	Fuel Flow	Percent Power	ISA - 30° C (-31° C)	ISA (-1° C)	ISA + 30° C (29° C)
MAP	RPM	GPH	PWR	KTAS	KTAS	KTAS
29.0-29.5	2500	17.6	85%	172	178	184
26.0-28.0	2500	16.0	75%	164	170	176
22.0-25.0	2500	14.0	65%	156	162	167

## CRUISE PERFORMANCE (CONT)

10000 Feet Pressure Altitude						
Manifold Pressure	Engine Speed	Fuel Flow	Percent Power	ISA - 30° C (-35° C)	ISA (-5° C)	ISA + 30° C (25° C)
MAP	RPM	GPH	PWR	KTAS	KTAS	KTAS
29.0-29.5	2500	17.6	85%	175	182	188
26.0-28.0	2500	16.0	75%	167	174	180
22.0-25.0	2500	14.0	65%	159	165	171

12000 Feet Pressure Altitude						
Manifold Pressure	Engine Speed	Fuel Flow	Percent Power	ISA - 30° C (-39° C)	ISA (-9° C)	ISA + 30° C (21° C)
MAP	RPM	GPH	PWR	KTAS	KTAS	KTAS
29.0-29.5	2500	17.6	85%	178	186	194
26.0-28.0	2500	16.0	75%	171	177	184
22.0-25.0	2500	14.0	65%	162	168	174

14000 Feet Pressure Altitude						
Manifold Pressure	Engine Speed	Fuel Flow	Percent Power	ISA - 30° C (-43° C)	ISA (-13° C)	ISA + 30° C (17° C)
MAP	RPM	GPH	PWR	KTAS	KTAS	KTAS
29.0-29.5	2500	17.6	85%	182	189	196
26.0-28.0	2500	16.0	75%	174	181	187
22.0-25.0	2500	14.0	65%	165	172	178

16000 Feet Pressure Altitude						
Manifold Pressure	Engine Speed	Fuel Flow	Percent Power	ISA - 30° C (-47° C)	ISA (-17° C)	ISA + 30° C (13° C)
MAP	RPM	GPH	PWR	KTAS	KTAS	KTAS
29.0-29.5	2500	17.6	85%	186	193	200
26.0-28.0	2500	16.0	75%	178	185	191
22.0-25.0	2500	14.0	65%	169	175	182

18000 Feet Pressure Altitude						
Manifold Pressure	Engine Speed	Fuel Flow	Percent Power	ISA - 30° C (-51° C)	ISA (-21° C)	ISA + 30° C (9° C)
MAP	RPM	GPH	PWR	KTAS	KTAS	KTAS
29.0-29.5	2500	17.6	85%	190	198	205
26.0-28.0	2500	16.0	75%	181	189	196
22.0-25.0	2500	14.0	65%	172	179	185



# CRUISE PERFORMANCE (CONT)

20000 Feet Pressure Altitude						
Manifold Pressure	Engine Speed	Fuel Flow	Percent Power	ISA - 30° C (-55° C)	ISA (-25° C)	ISA + 30° C (5° C)
MAP	RPM	GPH	PWR	KTAS	KTAS	KTAS
29.0-29.5	2500	17.6	85%	193	201	209
29.0-29.5	2500	16.8	80%	189	197	204
26.0-28.0	2500	16.0	75%	185	192	199
22.0-25.0	2500	14.0	65%	175	182	189

22000 Feet Pressure Altitude						
Manifold Pressure	Engine Speed	Fuel Flow	Percent Power	ISA - 30° C (-59° C)	ISA (-29° C)	ISA + 30° C (1° C)
MAP	RPM	GPH	PWR	KTAS	KTAS	KTAS
29.0-29.5	2500	17.6	85%	197	205	213
29.0-29.5	2500	16.8	80%	193	201	208
26.0-28.0	2500	16.0	75%	188	196	203
22.0-25.0	2500	14.0	65%	178	186	193

24000 Feet Pressure Altitude						
Manifold Pressure	Engine Speed	Fuel Flow	Percent Power	ISA - 30° C (-63° C)	ISA (-33° C)	ISA + 30° C (-3° C)
MAP	RPM	GPH	PWR	KTAS	KTAS	KTAS
29.0-29.5	2500	17.6	85%	201	209	217
29.0-29.5	2500	16.8	80%	196	205	212
26.0-28.0	2500	16.0	75%	192	200	207
22.0-25.0	2500	14.0	65%	182	189	196

25000 Feet Pressure Altitude						
Manifold Pressure	Engine Speed	Fuel Flow	Percent Power	ISA - 30° C (-65° C)	ISA (-35° C)	ISA + 30° C (-5° C)
MAP	RPM	GPH	PWR	KTAS	KTAS	KTAS
29.0-29.5	2500	17.6	85%	203	211	219
29.0-29.5	2500	16.8	80%	198	207	215
26.0-28.0	2500	16.0	75%	193	202	209
22.0-25.0	2500	14.0	65%	183	191	198

## LANDING DISTANCE

<b>WEIGHT:</b> 3400 LB	<b>Headwind:</b> Subtract 10% for each 13 knots headwind.
<b>Speed over 50 Ft Obstacle:</b> 77 KIAS	<b>Tailwind:</b> Add 10% for each 2 knots tailwind up to 10 knots.
<b>Flaps:</b> 100%	<b>Runway Slope:</b> Reference Notes
<b>Power:</b> Idle	<b>Dry Grass:</b> Add 20% to Ground Roll
<b>Runway:</b> Dry, Paved, Level	<b>Wet Grass:</b> Add 60% to Ground Roll

PRESS ALT FT	DISTANCE FT	TEMPERATURE ~ °C					ISA
		0	10	20	30	40	
SL	Grnd Roll	1082	1121	1161	1200	1240	1141
	Total	2262	2316	2372	2428	2485	2344
1000	Grnd Roll	1122	1163	1204	1245	1286	1175
	Total	2317	2374	2433	2492	2551	2391
2000	Grnd Roll	1163	1206	1248	1291	1334	1210
	Total	2375	2436	2497	2559	2621	2441
3000	Grnd Roll	1207	1251	1295	1339	1384	1247
	Total	2437	2501	2565	2630	2696	2493
4000	Grnd Roll	1252	1298	1344	1390	1436	1285
	Total	2503	2569	2637	2705	2774	2548
5000	Grnd Roll	1300	1348	1395	1443	1490	1324
	Total	2572	2642	2713	2785	2857	2605
6000	Grnd Roll	1350	1399	1449	1498	1547	1365
	Total	2645	2719	2794	2869	2945	2665
7000	Grnd Roll	1402	1453	1504	1556	1607	1408
	Total	2723	2800	2879	2958	3038	2728
8000	Grnd Roll	1456	1509	1563	1616	1669	1452
	Total	2805	2887	2969	3052	3136	2794
9000	Grnd Roll	1513	1569	1624	1679	1735	1497
	Total	2892	2978	3064	3152	3240	2863
10000	Grnd Roll	1573	1630	1688	1746	1803	1545
	Total	2984	3074	3165	3257	3350	2936

LANDING

## WEIGHT AND BALANCE

### Loading Calculations

For Moment/1000, refer to Loading Data table on following page.

	Description	Weight	Moment/1000
1.	Empty Weight <i>Includes unusable fuel and full oil</i>		
2.	Front Seats Occupants <i>Pilot and Passenger</i>		
3.	Rear Seats Occupants		
4.	Baggage <i>130 lb maximum</i>		
5.	<b>Zero Fuel Condition</b> <i>Subtotal items 1 thru 4</i>		
6.	Fuel Load <i>92 Gallon @6.0 lb/gal. maximum</i>		
7.	<b>Ramp Weight</b> <i>Subtotal items 5 and 6</i>		
8.	Fuel for start, taxi, and runup <i>Normally 9 lb at avg. mmnt of 1394</i>	-	-
9.	<b>Takeoff Weight</b> <i>Subtract Item 8 from item 7</i>		

### Calculation Instructions

- Enter the current basic empty weight and moment from the aircraft's Weight and Balance Record.
- Enter the total weight and moment/1000 for the front seat occupants from the adjacent Loading Data Table.
- Enter the total weight and moment/1000 for the rear seat occupants from the adjacent Loading Data Table.
- Enter the total weight and moment/1000 for the baggage from the adjacent Loading Data Table.
- If desired, subtotal the weight and moment/1000 entries from steps 1 - 4.
- Enter the weight and moment/1000 of usable fuel loaded on the airplane.
- Subtotal the weight and moment/1000.
- Enter values for typical start, taxi, and run-up operations of 9 pounds at an average moment/1000 of 1.39.
- Subtract step 8 weight and moment/1000 from the Ramp Weight to determine the Takeoff Weight and moment/1000.
  - Verify Takeoff Weight does not exceed the 3400 pounds.
  - Verify Moment/1000 does falls between the interpolated minimum and maximum values listed on the adjacent Moment Limits Table.



## WEIGHT AND BALANCE (CONTINUED)

### Loading Data

To complete Loading Calculations, use this table to determine the Moment/1000.

Weight LB	Fwd Pass FS 143.5	Aft Pass FS 180.0	Baggage FS 208.0	Fuel FS 154.9	Weight LB	Fwd Pass FS 143.5	Aft Pass FS 180.0	Fuel FS 154.9
20	2.9	3.6	4.2	3.1	300	43.1	54.0	46.5
40	5.7	7.2	8.3	6.2	320	45.9	57.6	49.6
60	8.6	10.8	12.5	9.3	340	48.8	61.2	52.7
80	11.5	14.4	16.6	12.4	360	51.7	64.8	55.8
100	14.4	18.0	20.8	15.5	380	54.5	68.4	58.9
120	17.2	21.6	25.0	18.6	400	57.4	72.0	62.0
140	20.1	25.2	27.04*	21.7	420	60.3	75.6	65.1
160	23.0	28.8		24.8	440	63.1	79.2	68.2
180	25.8	32.4		27.9	460			71.3
200	28.7	36.0		31.0	480			74.4
220	31.6	39.6		34.1	500			77.5
240	34.4	43.2		37.2	520			80.5
260	37.3	46.8		40.3	552**			85.5
280	40.2	50.4		43.4				

\*130 lb Maximum

\*\*92 U.S. Gallons Usable

### Moment Limits

Use this table to determine if Loading Calculations are within limits.

Weight LB	Moment/1000		Weight LB	Moment/1000	
	Minimum	Maximum		Minimum	Maximum
2200	304	326	2850	398	422
2250	311	333	2900	406	430
2300	318	341	2950	414	437
2350	326	348	3000	421	444
2400	333	355	3050	429	452
2450	340	363	3100	437	459
2500	347	370	3150	444	467
2550	354	378	3200	452	474
2600	362	385	3250	460	481
2650	369	392	3300	467	489
2700	375	400	3350	475	496
2750	383	407	3400	483	504
2800	390	415			

## WIND COMPONENTS

**Conditions:**

- Runway Heading ..... 10°
- Wind Direction ..... 60°
- Wind Velocity ..... 15 Knots

**Example: (See Chart ▶ ▶ ▶)**

- Wind/Flight Path Angle ..... 50°
- Crosswind Component ..... 12 Knots
- Headwind Component ..... 10 Knots

• Note •

- The maximum demonstrated crosswind is 20 knots. Value not considered limiting.

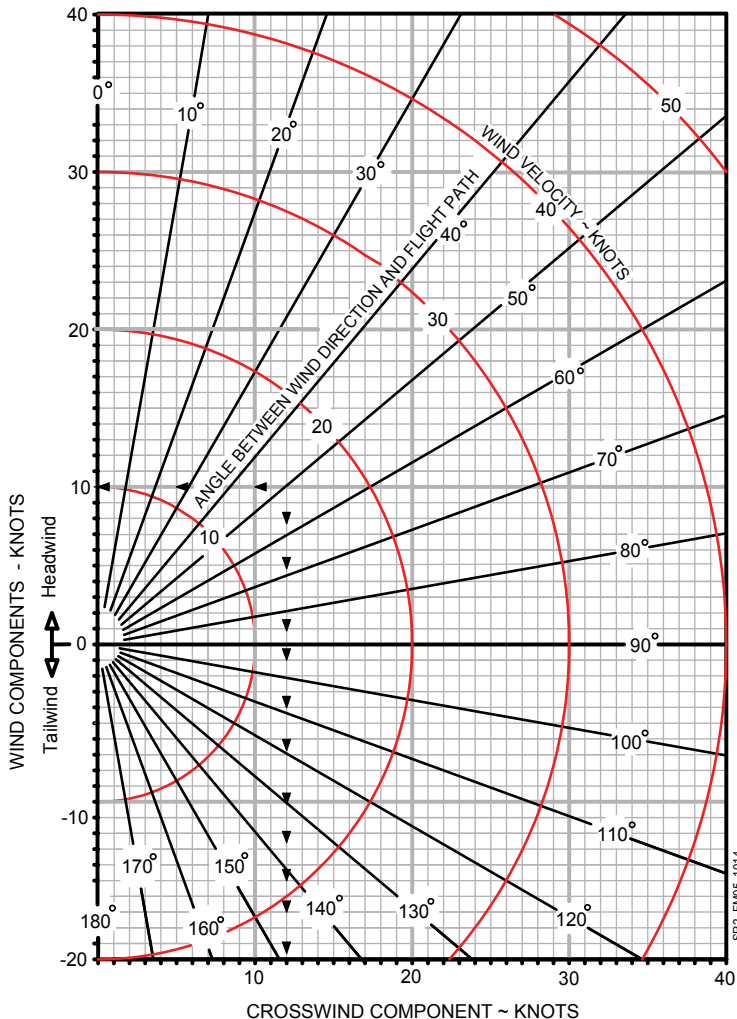



**Cirrus Design**  
**Abnormal Checklist**

**FLIGHT ENVIRONMENT ..... A-1**  
 Engine Failure In Flight - Inadvertently Retarding ..... A-1  
 Inadvertent Icing Encounter..... A-1  
 Inadvertent IMC Encounter..... A-1  
 Door Open In Flight ..... A-1

**ABNORMAL LANDINGS ..... A-2**  
 Landing With Failed Brakes ..... A-2  
 Landing With Flat Tire ..... A-2

**ENGINE SYSTEM ..... A-3**  
 Low Idle Oil Pressure ..... A-3  
 Starter Engaged Annunciation ..... A-3  
 Alternate Air Door Open ..... A-3

**FUEL SYSTEM..... A-4**  
 Left Fuel Tank Quantity..... A-4  
 Right Fuel Tank Quantity ..... A-4  
 Fuel Filter in Bypass Mode ..... A-4

**ELECTRICAL SYSTEM ..... A-5**  
 Battery 1 Current Sensor..... A-5

**INTEGRATED AVIONICS SYSTEM..... A-6**  
 Avionics Switch Off..... A-6  
 Flight Displays Too Dim ..... A-6  
 PFD Cooling Fan Failure ..... A-6  
 MFD Cooling Fan Failure..... A-6

**PITOT STATIC SYSTEM..... A-7**  
 Pitot Static Malfunction ..... A-7  
 Pitot Heat Current Sensor Annunciation..... A-7  
 Pitot Heat Required Annunciation ..... A-8  
 Pitot Heat Required Annunciation ..... A-8

**FLIGHT CONTROL SYSTEM..... A-9**  
 Electric Trim/Autopilot Failure ..... A-9  
 Flap System Exceedance ..... A-9

**LANDING GEAR SYSTEM ..... A-10**  
 Brake Failure During Taxi ..... A-10  
 Left/Right Brake Over-Temperature..... A-10

**OTHER CONDITIONS..... A-11**  
 Aborted Takeoff ..... A-11  
 Parking Brake Engaged Annunciation ..... A-11  
 Communications Failure ..... A-11



**FLIGHT ENVIRONMENT**

**Engine Failure In Flight - Inadvertently Retarding Power Lever To Idle**

***Below 18,000 Feet***

Retarding power lever to idle at or near a full rich mixture setting may cause engine combustion to cease. Advancing the throttle should cause resumption of normal engine operation.

Retarding power lever to idle at or near a very lean mixture setting may cause engine combustion to cease. Using the boost pump in the LOW BOOST position during approach and landing will prevent this condition.

***Above 18,000 Feet***

If manifold pressure is reduced below 15" Hg and Power Lever positioned close to or at idle, engine may cease combustion. Upon advancing Power Lever, if wind milling engine does not immediately regain power, perform the following:

1. Electric Fuel Pump .....LOW BOOST
2. Power Lever ..... ½ OPEN
3. Mixture Control ..... FULL RICH, then LEAN until engine starts  
*then slowly advance to FULL RICH*
4. Power Lever .....AS REQUIRED
5. Mixture .....AS REQUIRED
6. Electric Fuel Pump .....AS REQUIRED

**Inadvertent Icing Encounter**

1. Pitot Heat ..... ON
2. Exit icing conditions. Turn back or change altitude.
3. Cabin Heat ..... MAXIMUM
4. Windshield Defrost ..... FULL OPEN

**Inadvertent IMC Encounter**

1. Airplane Control ..... Establish Straight and Level Flight
2. Autopilot ..... Engage to hold Heading and Altitude
3. Heading ..... Reset to initiate 180° turn

**Door Open In Flight**

1. Airspeed ..... REDUCE TO 80 – 90 KIAS
2. Land as soon as practical.

## ABNORMAL LANDINGS

### Landing With Failed Brakes

#### ***One brake inoperative***

1. Land on the side of runway corresponding to the inoperative brake.
2. Maintain directional control using rudder and working brake.

#### ***Both brakes inoperative***

1. Divert to the longest, widest runway with the most direct headwind.
2. Land on downwind side of the runway.
3. Use the rudder for obstacle avoidance.
4. Perform *Emergency Engine Shutdown on Ground* checklist.

### Landing With Flat Tire

#### ***Main Gear***

1. Land on the side of the runway corresponding to the good tire.
2. Maintain directional control with the brakes and rudder.
3. Do not taxi. Stop the airplane and perform a normal engine shutdown.

#### ***Nose Gear***

1. Land in the center of the runway.
2. Hold the nosewheel off the ground as long as possible.
3. Do not taxi. Stop the airplane and perform a normal engine shutdown.

## ENGINE SYSTEM

### Low Idle Oil Pressure

**OIL PRESS**

Oil pressure between 10 psi and 30 psi at or above 1000 RPM

1. If In-Flight..... LAND AS SOON AS PRACTICAL

### Starter Engaged Annunciation

**START ENGAGE**

Starter stuck engaged. MCU detects 24 VDC to Starter 15 seconds after initial engagement.

#### ***On-Ground***

1. STARTER Circuit Breaker..... PULL

#### ***In-Flight***

1. STARTER Circuit Breaker..... PULL
2. Land as soon as practical.

### Alternate Air Door Open

**ALT AIR OPEN**

Alternate air door is open.

1. Momentarily retard power lever to re-latch door.

## FUEL SYSTEM

### Left Fuel Tank Quantity

**L FUEL QTY**

Left fuel quantity is less than or equal to 18 gallons.

1. Left Fuel Quantity Gage .....CHECK  
*If left fuel quantity indicates less than or equal to 18 gallons:*
  - a. If On-Ground ..... REFUEL PRIOR TO FLIGHT
  - b. If In-Flight .....CONTINUE, MONITOR*If left fuel quantity indicates more than 18 gallons:*
  - a. If On-Ground .....CORRECT PRIOR TO FLIGHT
  - b. If In-Flight .....CONTINUE, MONITOR

### Right Fuel Tank Quantity

**R FUEL QTY**

Right fuel quantity is less than or equal to 18 gallons.

1. Right Fuel Quantity Gage ..... CHECK  
*If right fuel quantity indicates less than or equal to 18 gallons:*
  - a. If On-Ground ..... REFUEL PRIOR TO FLIGHT
  - b. If In-Flight .....CONTINUE, MONITOR*If right fuel quantity indicates more than 18 gallons:*
  - a. If On-Ground .....CORRECT PRIOR TO FLIGHT
  - b. If In-Flight .....CONTINUE, MONITOR

### Fuel Filter in Bypass Mode

**FUEL FILTER**

The fuel filter is in bypass mode. The fuel filter element must be replaced.

1. If In-Flight..... LAND AS SOON AS PRACTICAL
2. Replace fuel filter element prior to next flight.

FUEL SYSTEM

**ELECTRICAL SYSTEM****Battery 1 Current Sensor****BATT 1**

Battery 1 current is discharging at a rate greater than 4 amps for 30 seconds or more.

1. Land as soon as practical.

## INTEGRATED AVIONICS SYSTEM

### Avionics Switch Off

**AVIONICS OFF**

The AVIONICS master switch is off.

1. AVIONICS Switch ..... ON, AS REQUIRED

### Flight Displays Too Dim

1. INSTRUMENT dimmer knob ..... OFF  
*If Flight Displays are not controllable with INSTRUMENT dimmer knob:*
2. CABIN LIGHTS Circuit Breaker ..... PULL
3. Revert to standby instruments with flashlight for illumination.

### PFD Cooling Fan Failure

**PFD 1 FAN FAIL**

The cooling fan for the PFD is inoperative.

1. AVIONICS FAN 2 Circuit Breaker ..... CYCLE  
*If annunciation does not extinguish:*
  - a. Hot cabin temperatures..... LAND AS SOON AS PRACTICLE
  - b. Cool cabin temperatures .....CONTINUE, MONITOR

### MFD Cooling Fan Failure

**MFD FAN FAIL**

The cooling fan for the MFD is inoperative.

1. AVIONICS FAN 1 Circuit Breaker ..... CYCLE  
*If annunciation does not extinguish:*
  - a. High cabin temperatures.... LAND AS SOON AS PRACTICLE
2. Low cabin temperatures .....CONTINUE, MONITOR

**PITOT STATIC SYSTEM**

**Pitot Static Malfunction**

***Static Source Blocked***

If erroneous readings of the static source instruments (airspeed, altimeter and vertical speed) are suspected, the alternate static source valve, on side of console near pilot's right ankle, should be opened to supply static pressure from the cabin to these instruments. With the alternate static source on, adjust indicated airspeed slightly during climb or approach according to the Airspeed Calibration (Alternate Static Source) table in Section 5 as appropriate for vent/ heater configuration.

1. Pitot Heat..... ON
2. Alternate Static Source..... OPEN

***Pitot Tube Blocked***

If only the airspeed indicator is providing erroneous information, and in icing conditions, the most probable cause is Pitot ice. If setting Pitot Heat ON does not correct the problem, descend to warmer air. If an approach must be made with a blocked Pitot tube, use known pitch and power settings and the GPS groundspeed indicator, taking surface winds into account.

1. Pitot Heat..... ON

**Pitot Heat Current Sensor Annunciation**



Pitot heat failure. Displayed when Pitot heat switch is ON and Pitot heat current is not detected.

1. Pitot Circuit Breaker..... CYCLE
2. Pitot Heat..... CYCLE OFF, ON

*If inadvertent icing encountered, perform Inadvertent Icing Encounter Emergency Checklist and:*

- a. Airspeed..... EXPECT NO RELIABLE INDICATION
- b. Exit icing conditions using attitude, altitude, and power instruments.

**Pitot Heat Required Annunciation**

**PITOT HT RQD**

Displayed 20 seconds after system detects OAT is less than 41°F (5°C) and Pitot Heat Switch is OFF.

1. Pitot Heat.....ON

**Pitot Heat Required Annunciation**

**PITOT HT OFF**

Displayed when system detects OAT is above than 41°F (5°C) and Pitot Heat Switch is OFF.

1. Pitot Heat.....ON

**FLIGHT CONTROL SYSTEM**

**Electric Trim/Autopilot Failure**

1. Airplane Control..... MAINTAIN MANUALLY
2. Autopilot (if engaged)..... Disengage  
*If Problem Is Not Corrected:*
3. Circuit Breakers ..... PULL AS Required
  - PITCH TRIM
  - ROLL TRIM
  - AUTOPILOT
4. Power Lever .....AS REQUIRED
5. Control Yoke .....MANUALLY HOLD PRESSURE
6. Land as soon as practical.

**Flap System Exceedance**

**FLAPS**

Flaps are extended beyond airspeed limitations.

Flaps at 100%, airspeed greater than 109 KIAS for 5 seconds or more,  
OR

Flaps at 50%, airspeed greater than 124 KIAS for 5 seconds or more.

1. Airspeed ..... REDUCE  
*or*
1. Flaps..... RETRACT

## LANDING GEAR SYSTEM

### Brake Failure During Taxi

1. Engine Power .....AS REQUIRED
2. Directional Control ..... MAINTAIN WITH RUDDER
3. Brake Pedal(s) ..... PUMP  
*If directional control can not be maintained:*
4. Mixture ..... CUTOFF

### Left/Right Brake Over-Temperature

#### BRAKE TEMP

Brake temperature is between 270°F and 293°F for more than 5 seconds. Refer to Section 10 - Safety Information: Taxiing, Steering, and Braking Practices for additional information.

1. Stop aircraft and allow the brakes to cool.

**OTHER CONDITIONS**

**Aborted Takeoff**

- 1. Power Lever ..... IDLE
- 2. Brakes ..... AS REQUIRED

**Parking Brake Engaged Annunciation**

**PARK BRAKE**

Parking brake is set.

- 1. Parking Brake ..... RELEASE
- 2. Monitor CAS for BRAKE TEMP Caution. Stop aircraft and allow the brakes to cool if necessary.

**Communications Failure**

- 1. Switches, Controls ..... CHECK
- 2. Frequency ..... CHANGE
- 3. Circuit Breakers ..... CHECK
- 4. Headset ..... CHANGE
- 5. Hand Held Microphone ..... CONNECT



## *Cirrus Design* **Emergency Checklist**

<b>AIRSPEDS FOR EMERGENCY OPERATIONS.....</b>	<b>E-1</b>
Maneuvering Speed: .....	E-1
Best Glide: .....	E-1
Emergency Landing (Engine-Out): .....	E-1
Maximum Glide.....	E-1
<b>ENGINE FAILURES .....</b>	<b>E-2</b>
Engine Failure On Takeoff (Low Altitude) .....	E-2
Engine Failure In Flight.....	E-2
Engine Airstart.....	E-2
<b>SMOKE AND FIRE.....</b>	<b>E-3</b>
Engine Fire In Flight .....	E-3
Cabin Fire In Flight .....	E-3
Wing Fire In Flight .....	E-4
Engine Fire During Start.....	E-4
Smoke and Fume Elimination.....	E-4
<b>FORCED LANDINGS .....</b>	<b>E-5</b>
Emergency Landing Without Engine Power .....	E-5
Emergency Descent .....	E-5
Ditching.....	E-5
Landing Without Elevator Control .....	E-5
<b>PROPULSION SYSTEM .....</b>	<b>E-6</b>
Unexpected Loss Of Manifold Pressure .....	E-6
Engine Partial Power Loss.....	E-6
Oil Pressure Out of Range .....	E-6
High Cylinder Head Temperature .....	E-7
Engine Speed High.....	E-7
Oil Temperature High.....	E-7
Turbine Inlet Temperature High.....	E-8
Manifold Pressure High .....	E-8
<b>FUEL SYSTEM.....</b>	<b>E-8</b>
High Fuel Flow.....	E-8
Low Fuel Quantity.....	E-8
<b>ELECTRICAL SYSTEM .....</b>	<b>E-9</b>
High Voltage on Main Bus 1 or Main Bus 2 .....	E-9
Low Voltage on Essential Bus .....	E-9
Low Alternator 1 Output.....	E-9
<b>INTEGRATED AVIONICS SYSTEM.....</b>	<b>E-10</b>
Attitude & Heading Reference System (AHRS) Failure .....	E-10
Air Data Computer (ADC) Failure .....	E-10
PFD Display Failure.....	E-10
<b>UNUSUAL ATTITUDE.....</b>	<b>E-10</b>
Inadvertent Spin Entry.....	E-10
Inadvertent Spiral Dive During IMC Flight .....	E-10
<b>OTHER EMERGENCIES.....</b>	<b>E-11</b>
Power Lever Linkage Failure .....	E-11
Emergency Engine Shutdown On Ground .....	E-11
CAPS Deployment.....	E-11



# Emergency Checklist

## AIR SPEEDS FOR EMERGENCY OPERATIONS

### Maneuvering Speed:

3400 lb..... 133 KIAS

### Best Glide:

3400 lb..... 88 KIAS

2900 lb..... 87 KIAS

### Emergency Landing (Engine-Out):

Flaps Up ..... 90 KIAS

Flaps 50%..... 85 KIAS

Flaps 100%..... 80 KIAS

### Maximum Glide

*Glide Ratio ≈ 9.6 : 1*

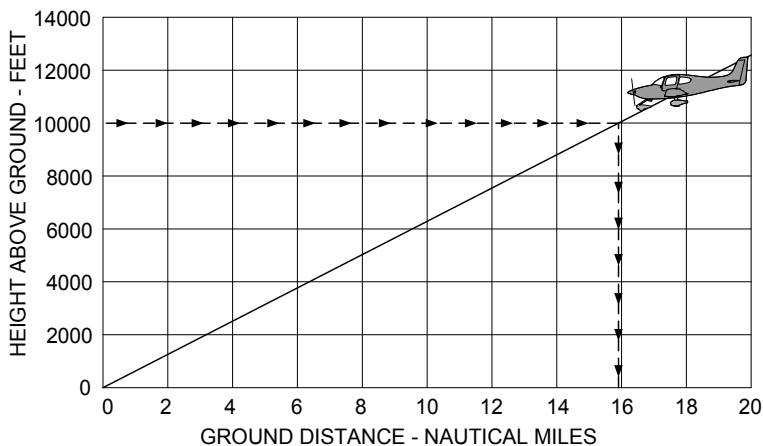

SR2\_FM03\_1391

Note: Checklist steps emphasized by underlining such as this:

1. Best Glide Speed..... ESTABLISH  
*should be memorized for accomplishment without reference to the procedure.*

## ENGINE FAILURES

### Engine Failure On Takeoff (Low Altitude)

1. Best Glide or Landing Speed (as appropriate) ..... ESTABLISH
2. Mixture ..... CUTOFF
3. Fuel Selector ..... OFF
4. Ignition Switch ..... OFF
5. Flaps ..... AS REQUIRED

*If time permits:*

6. Power Lever ..... IDLE
7. Fuel Pump ..... OFF
8. Bat-Alt Master Switches ..... OFF
9. Seat Belts ..... ENSURE SECURED

### Engine Failure In Flight

1. Best Glide Speed ..... ESTABLISH
2. Mixture ..... AS REQUIRED
3. Fuel Selector ..... SWITCH TANKS
4. Fuel Pump ..... BOOST
5. Alternate Induction Air ..... ON
6. Ignition Switch ..... CHECK, BOTH
7. If no start, perform *Engine Airstart* or *Forced Landing* checklist.

### Engine Airstart

1. Bat Master Switches ..... ON
2. Power Lever ..... 1/2" OPEN
3. Mixture ..... RICH, AS REQ'D
4. Fuel Selector ..... SWITCH TANKS
5. Ignition Switch ..... BOTH
6. Fuel Pump ..... BOOST
7. Alternate Induction Air ..... ON
8. Alt Master Switches ..... OFF
9. Starter (Propeller not Windmilling) ..... ENGAGE
10. Power Lever ..... slowly INCREASE
11. Alt Master Switches ..... ON
12. If no start, perform *Forced Landing* checklist.



**SMOKE AND FIRE**

**Engine Fire In Flight**

1. Mixture ..... CUTOFF
2. Fuel Pump ..... OFF
3. Fuel Selector ..... OFF
4. Airflow Selector ..... OFF
5. Power Lever ..... IDLE
6. Ignition Switch ..... OFF
7. Cabin Doors ..... PARTIALLY OPEN
8. Land as soon as possible.

**Cabin Fire In Flight**

1. Bat-Alt Master Switches ..... OFF, AS REQ'D
2. Fire Extinguisher ..... ACTIVATE  
*If airflow is not sufficient to clear smoke or fumes from cabin:*
3. Cabin Doors ..... PARTIALLY OPEN
4. Avionics Power Switch ..... OFF
5. All other switches ..... OFF
6. Land as soon as possible.  
*If setting master switches off eliminated source of fire or fumes and airplane is in night, weather, or IFR conditions:*
7. Airflow Selector ..... OFF
8. Bat-Alt Master Switches ..... ON
9. Avionics Power Switch ..... ON
10. Activate required systems one at a time. Pause several seconds between activating each system to isolate malfunctioning system. Continue flight to earliest possible landing with malfunctioning system off. Activate only the minimum amount of equipment necessary to complete a safe landing.
11. Temperature Selector ..... COLD
12. Vent Selector ..... FEET/PANEL/DEFROST POSITION
13. Airflow Selector ..... SET FAN SPEED TO FULL ON (3) POSITION
14. Panel Eyeball Outlets ..... OPEN

SMOKE AND FIRE

**Wing Fire In Flight**

- 1. Pitot Heat Switch ..... OFF
- 2. Navigation Light Switch ..... OFF
- 3. Strobe Light Switch..... OFF
- 4. If possible, side slip to keep flames away from fuel tank and cabin.
- 5. Land as soon as possible.

**Engine Fire During Start**

- 1. Mixture..... CUTOFF
- 2. Fuel Pump ..... OFF
- 3. Fuel Selector ..... OFF
- 4. Power Lever..... FORWARD
- 5. Starter..... CRANK
- 6. If flames persist, perform *Emergency Engine Shutdown on Ground* and *Emergency Ground Egress* checklists.

**Smoke and Fume Elimination**

- 1. Temperature Selector ..... COLD
- 2. Vent Selector ..... FEET/PANEL/DEFROST POSITION
- 3. Airflow Selector..... SET FAN SPEED TO FULL ON (3) POSITION  
*If source of smoke and fume is firewall forward:*
  - a. Airflow Selector ..... OFF
- 4. Panel Eyeball Outlets ..... OPEN
- 5. Prepare to land as soon as possible.  
*If airflow is not sufficient to clear smoke or fumes from cabin:*
- 6. Cabin Doors..... PARTIALLY OPEN

SMOKE AND FIRE



## FORCED LANDINGS

### Emergency Landing Without Engine Power

1. Best Glide Speed..... ESTABLISH
2. Radio .....Transmit (121.5 MHz) MAYDAY
3. Transponder.....SQUAWK 7700
4. If off airport, ELT .....ACTIVATE
5. Power Lever..... IDLE
6. Mixture.....CUTOFF
7. Fuel Selector ..... OFF
8. Ignition Switch ..... OFF
9. Fuel Pump ..... OFF
10. Flaps (when landing is assured) ..... 100%
11. Master Switches ..... OFF
12. Seat Belt(s)..... SECURED

### Emergency Descent

1. Power Lever..... IDLE
2. Mixture.....AS REQUIRED
3. Airspeed .....  $V_{NE}$  (200 KIAS)

### Ditching

1. Radio .....Transmit (121.5 MHz) MAYDAY  
giving location and intentions
2. Transponder.....SQUAWK 7700
3. CAPS.....ACTIVATE
4. Airplane ..... EVACUATE
5. Flotation Devices .....INFLATE WHEN CLEAR OF AIRPLAN

### Landing Without Elevator Control

1. Flaps..... SET 50%
2. Trim..... SET 80 KIAS
3. Power..... AS REQUIRED FOR GLIDE ANGLE

FORCED LANDINGS

**PROPULSION SYSTEM**

**Unexpected Loss Of Manifold Pressure**

1. Power Lever..... REDUCE  
to minimum setting required for continued flight.
2. Engine .....MONITOR  
Remain alert for the possibility of a fire in the engine compartment
3. Altitude.....DESCEND  
to the minimum safe altitude from which a landing may be most safely and expeditiously accomplished
4. Declare an emergency.

**Engine Partial Power Loss**

1. Fuel Pump .....**BOOST**
2. Fuel Selector .....**SWITCH TANKS**
3. Mixture.....**CHECK** appropriate for flight conditions
4. Power Lever..... **SWEEP**
5. Alternate Induction Air ..... **ON**
6. Ignition Switch ..... **BOTH, L, then R**
7. Land as soon as practical.

**Oil Pressure Out of Range**

**OIL PRESS**

1. Oil Pressure Gage .....**CHECK**  
*If pressure normal:*
  - a. Flight .....**CONTINUE, MONITOR***If pressure high:*
  - a. Oil Temperature Gage.....**CHECK**  
*If temperature low:*
    - (1) Engine .....**MONITOR OIL PRESS/TEMP***If temperature normal or high:*
    - (1) Flight..... **LAND AS SOON AS PRACTICAL**

PROPULSION SYSTEM

**PROPULSION SYSTEM (CONTINUED)**

**High Cylinder Head Temperature**

**CHT**

1. Power Lever ..... REDUCE
2. Airspeed ..... INCREASE
3. Annunciations and Engine Temperatures ..... MONITOR  
*If Caution or Warning annunciation is still illuminated:*
4. Power Lever ..... MINIMUM REQUIRED
5. Engine Instruments ..... MONITOR  
*If Caution annunciation only remains illuminated:*
  - a. Land as soon as practical.  
*If Warning annunciation remains illuminated:*
    - a. Land as soon as possible.

**Engine Speed High**

**RPM**

1. Tachometer .....CHECK  
*If engine speed normal:*
  - a. Flight .....CONTINUE, MONITOR  
*If engine speed high:*
    - b. Power ..... REDUCE
    - c. Airspeed ..... REDUCE UNTIL RPM BELOW 2700
2. Oil Pressure Gage .....CHECK

**Oil Temperature High**

**OIL TEMP**

1. Oil Temperature Gage .....CHECK  
*If temperature normal:*
  - a. Flight .....CONTINUE, MONITOR  
*If temperature high:*
    - a. Oil Pressure Gage ..... CHECK

PROPULSION SYSTEM

If pressure normal:

- (1) Power..... REDUCE
- (2) Airspeed ..... INCREASE
- (3) Oil Temperature Gage .....MONITOR

If low, See Oil Pressure Out of Range - OIL PRESS Warning checklist.

### Turbine Inlet Temperature High

**TIT**

- 1. Power.....ADJUST AS REQUIRED
- 2. Mixture.....ADJUST AS REQUIRED

### Manifold Pressure High

**MAN PRESSURE**

- 1. Reduce power reduce power to maintain no more than 32.0 in Hg.

## FUEL SYSTEM

### High Fuel Flow

**FUEL FLOW**

- 1. Engine Controls..... ADJUST  
*If FUEL FLOW Warning does not extinguish:*
- 2. Land as soon as practical.

### Low Fuel Quantity

**FUEL QTY**

- 1. Fuel Quantity Gages..... CHECK  
*If fuel quantity indicates less than or equal to 9 gallons:*
  - a. Flight ..... LAND AS SOON AS PRACTICAL*If fuel quantity indicates more than 9 gallons:*
  - a. Flight .....CONTINUE, MONITOR

FUEL SYSTEM

**ELECTRICAL SYSTEM**

**High Voltage on Main Bus 1 or Main Bus 2**

Conduct the following procedure if either of the annunciations listed below are displayed on the MFD.

**M BUS 1**

**M BUS 2**

1. Flight..... LAND AS SOON AS PRACTICAL

**Low Voltage on Essential Bus**

**ESS BUS**

1. Flight..... LAND AS SOON AS PRACTICAL

**Low Alternator 1 Output**

Conduct the following procedure if either of the annunciations listed below are displayed on the MFD.

**ALT 1**

**ALT 2**

1. Annunciated ALT Master Switch ..... OFF
2. Annunciated ALT Circuit Breaker..... CYCLE
3. Annunciated ALT Master Switch ..... ON  
*If alternator does not reset:*
4. Main Bus 1, 2, and Non-Essential Bus Loads ..... REDUCE
5. Voltage..... MONITOR
6. Annunciated ALT Master Switch ..... OFF
7. Land as soon as practical.

ELECTRICAL SYSTEM

**INTEGRATED AVIONICS SYSTEM****Attitude & Heading Reference System (AHRS) Failure**

1. AHRS Circuit Breaker ..... SET  
*If open, reset (close) circuit breaker. If circuit breaker opens again, do not reset.*
2. Revert to Standby Instruments (Altitude, Heading).
3. Land as soon as practical.

**Air Data Computer (ADC) Failure**

1. ADC Circuit Breaker ..... SET  
*If open, reset (close) circuit breaker. If circuit breaker opens again, do not reset.*
2. Revert to Standby Instruments (Altitude, Airspeed).
3. Land as soon as practical.

**PFD Display Failure**

1. Display Backup .....ACTIVATE

**UNUSUAL ATTITUDE****Inadvertent Spin Entry**

1. CAPS.....Activate

**Inadvertent Spiral Dive During IMC Flight**

1. Power Lever..... IDLE
2. Stop the spiral dive by using coordinated aileron and rudder control while referring to the attitude indicator and turn coordinator to level the wings.
3. Cautiously apply elevator back pressure to bring airplane to level flight attitude.
4. Trim for level flight.
5. Set power as required.
6. Use autopilot if functional otherwise keep hands off control yoke, use rudder to hold constant heading.
7. Exit IMC conditions as soon as possible.

**OTHER EMERGENCIES**

**Power Lever Linkage Failure**

1. Power Lever Movement ..... VERIFY
2. Power ..... SET if able
3. Flaps ..... SET if needed
4. Mixture ..... AS REQUIRED (full rich to cut-off)
5. Land as soon as possible.

**Emergency Engine Shutdown On Ground**

1. Power Lever ..... IDLE
2. Fuel Pump (if used) ..... OFF
3. Mixture ..... CUTOFF
4. Fuel Selector ..... OFF
5. Ignition Switch ..... OFF
6. Bat-Alt Master Switches ..... OFF

**CAPS Deployment**

As altitudes increase, true air speed of CAPS deployment increases. Higher true air speeds increase the parachute inflation loads. Slow to the minimum possible airspeed prior to deploying the CAPS.

1. Airspeed ..... MINIMUM POSSIBLE
2. Mixture (If time and altitude permit) ..... CUTOFF
3. Activation Handle Cover ..... REMOVE
4. Activation Handle ..... PULL STRAIGHT DOWN

*After deployment:*

5. Mixture ..... CHECK, CUTOFF
6. Fuel Selector ..... OFF
7. Bat-Alt Master Switches ..... OFF
8. Ignition Switch ..... OFF
9. Fuel Pump ..... OFF
10. ELT ..... ON
11. Seat Belts and Harnesses ..... TIGHTEN
12. Loose Items ..... SECURE
13. Assume emergency landing body position.
14. After airplane comes to a complete stop, evacuate quickly and move upwind.